

Am Weidenhof 3
D-52525 Heinsberg
Germany
T +49 (0) 2452 689-0
E sieben@jskv.de
//jskv.de

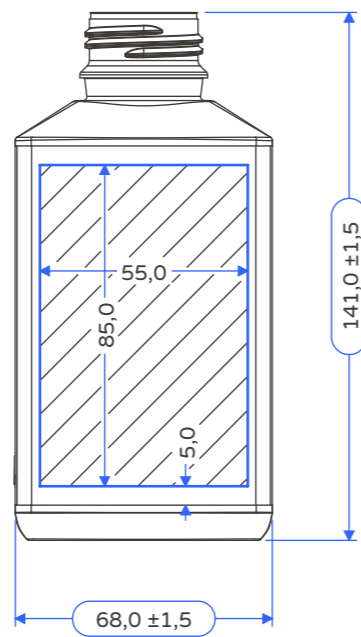

Neck : 32mm

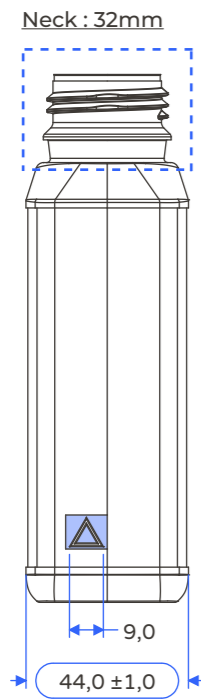
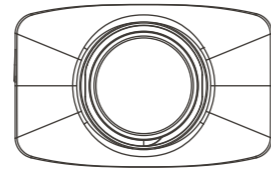
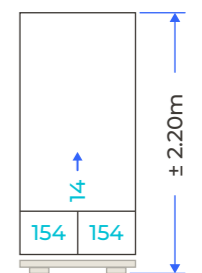
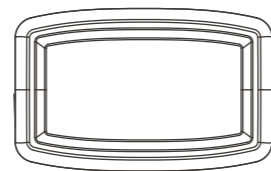
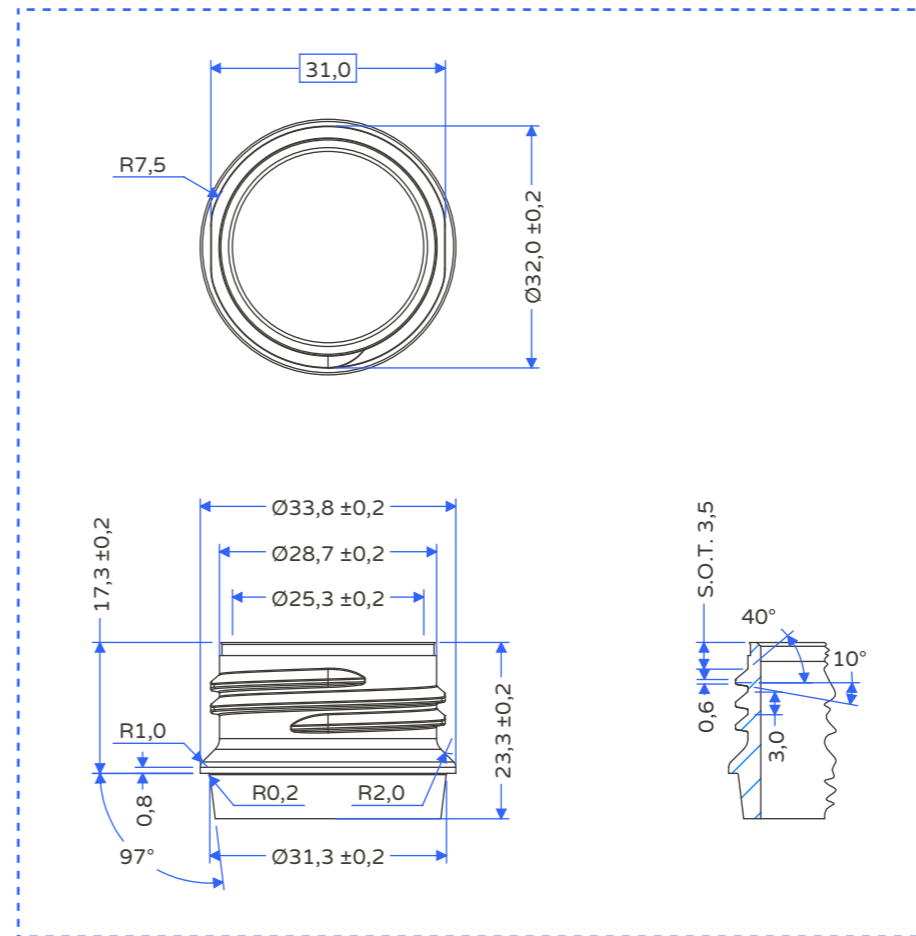

B0251.63 - POL 250 ml

Technical data sheet for mould manufacturing / Product sheet



» DIMENSIONS ARE IN MM
» TOLERANCES THAT ARE NOT SPECIFIED +/- 3MM
» THIS DRAWING IS PROPERTY OF JOHANN SIEBEN GMBH
» ANY INFORMATION CONTAINED HEREIN IS CONFIDENTIAL.